

P O T T E R Y B A R N

Chloe Console Table Assembly Instructions

Pre-Assembly:

- Please read all instructions carefully before beginning assembly
- This table requires two people to do the assembly.
- Do not fully tighten all bolts until all parts are in place. Failure to follow these instructions may cause the bolts to misalign or may cause difficulty during assembly.
- Use the parts and hardware lists to identify and separate each of the components included.
- Save all packing materials until the table is fully assembled to avoid accidentally discarding any small parts or hardware.

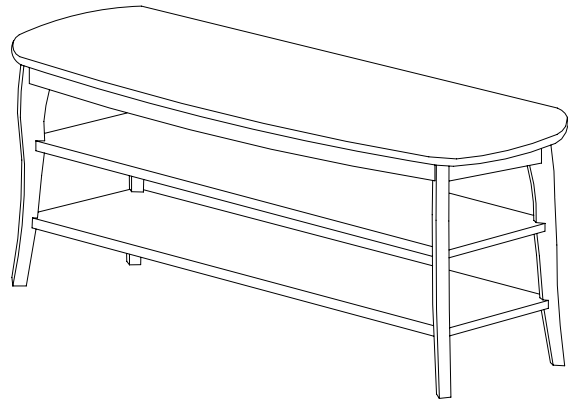

Parts Included:

(1) Tabletop - A	(2) Shelves - B	(4) Legs - C

Hardware Included:

(16) Flat Washer - D 	(16) Lock Washer - E 	(8) Allen Head Bolt (M6 x 60 mm)- F 	(1) Allen Key - G
(8) Nut - H 	(8) Fitting - I 	(1) Allen Wrench (3 mm thickness) - J 	

Assembly Instructions:

1. Insert the hanger bolts pre-connected to the leg (C) into the pre-drilled corner holes of the shelves (B). Insert fitting (I), flat washer (D), lock washer (E), and nut (H) into bolts. Use hand to secure. DO NOT FULLY TIGHTEN AT THIS TIME. (Fig. 1)

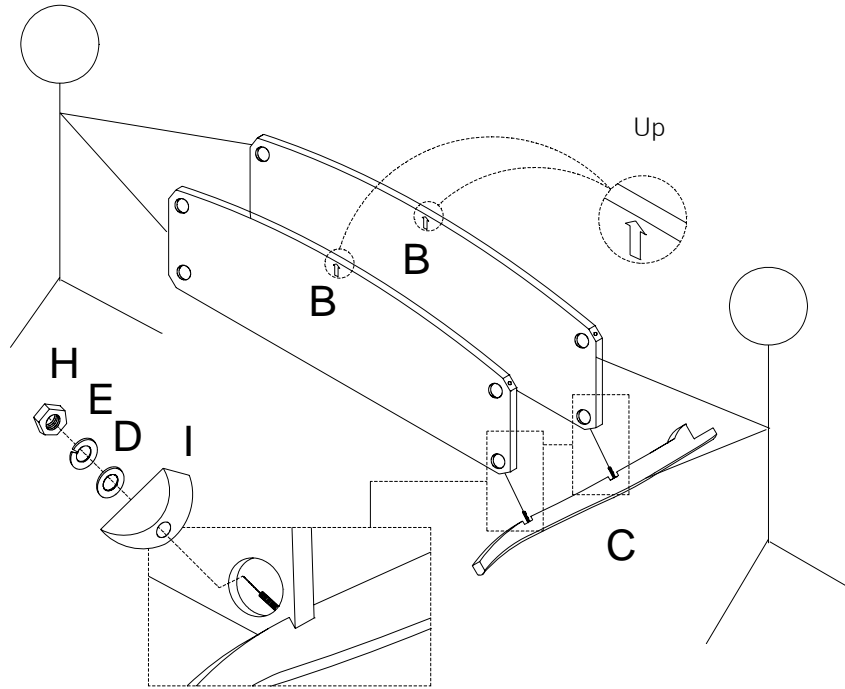

Fig. 1

2. Repeat step 1 with one leg (C) at the other end. (Fig. 2)

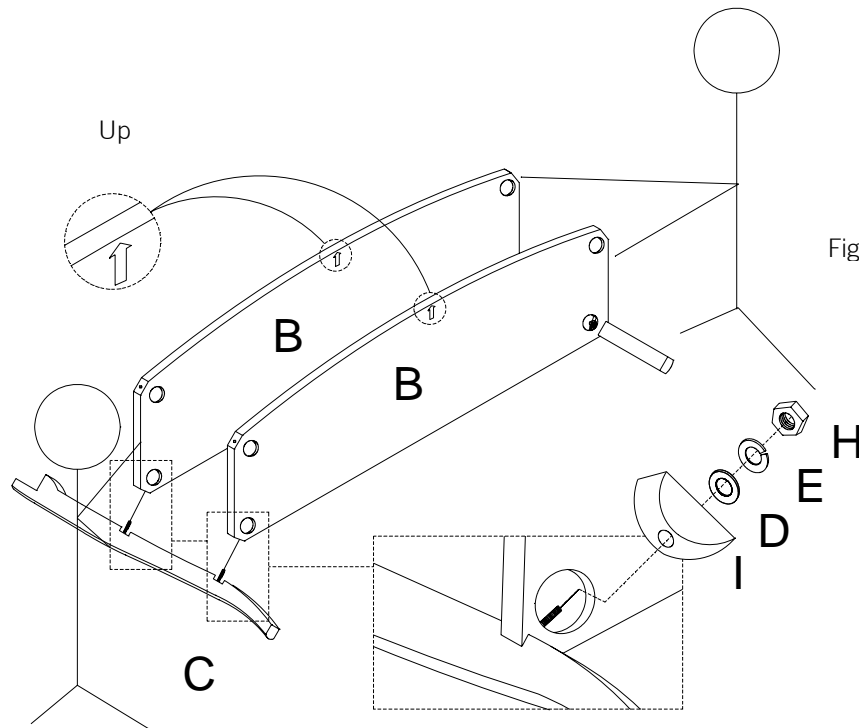
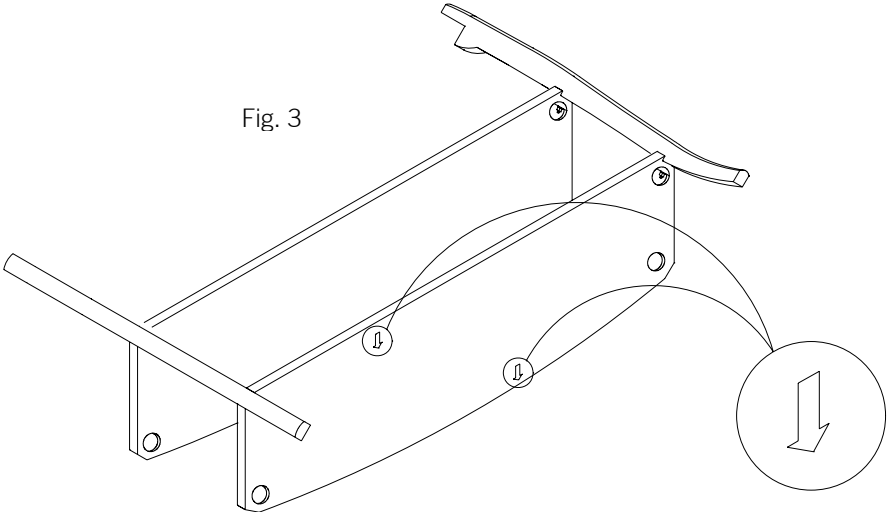
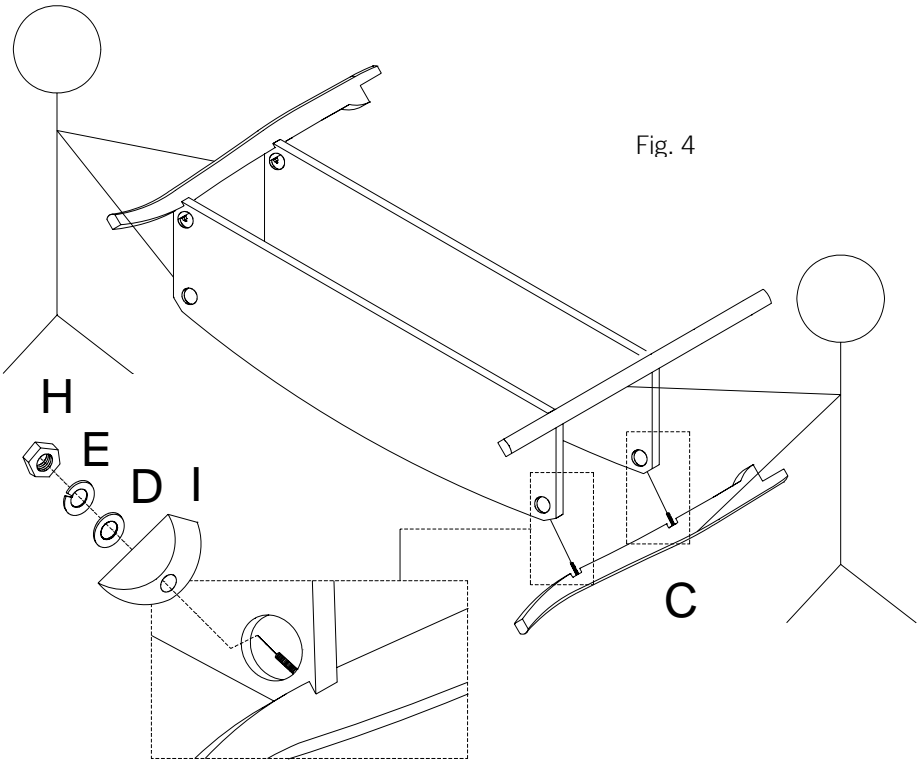

Fig. 2

3. Turn the assembled leg and shelf up. (Fig. 3)



4. Attach one leg (C) to the shelves from underneath as shown. Insert fitting (I), flat washer (D), lock washer (E), and nut (H) into bolts. Use hand to secure. DO NOT TIGHTEN FULLY AT THIS TIME. (Fig. 4)



5. Attach the remaining leg (C) to the shelves (B) using step 4 instructions. (Fig. 5)

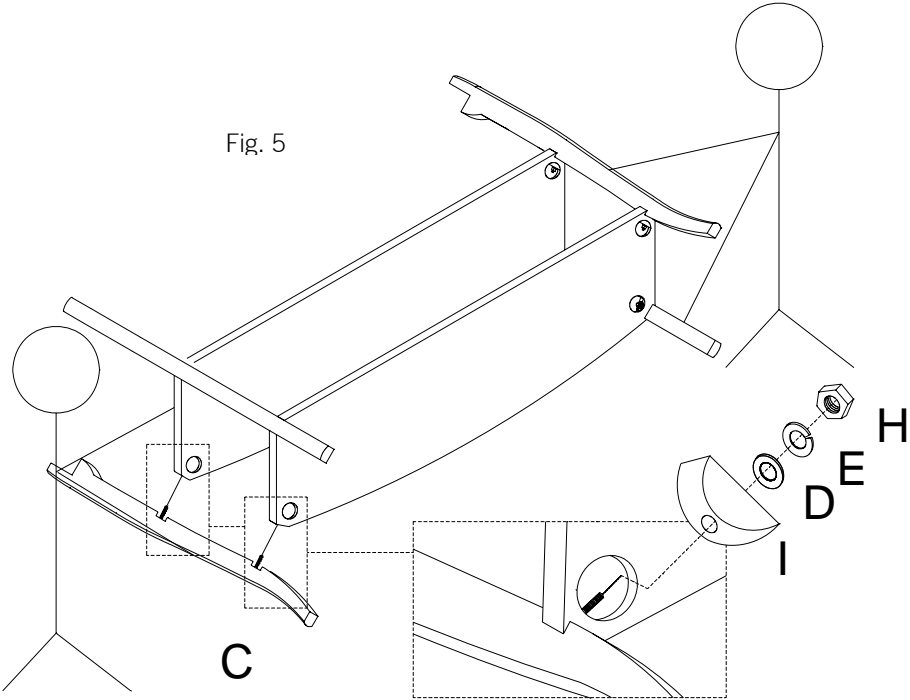

6. Lay the tabletop (A) upside down on a carpeted or scratch-free work surface (the foam shipped in the carton box works well). Attach the legs with shelves by aligning the legs with the corner braces on the tabletop (A). (Fig. 6)

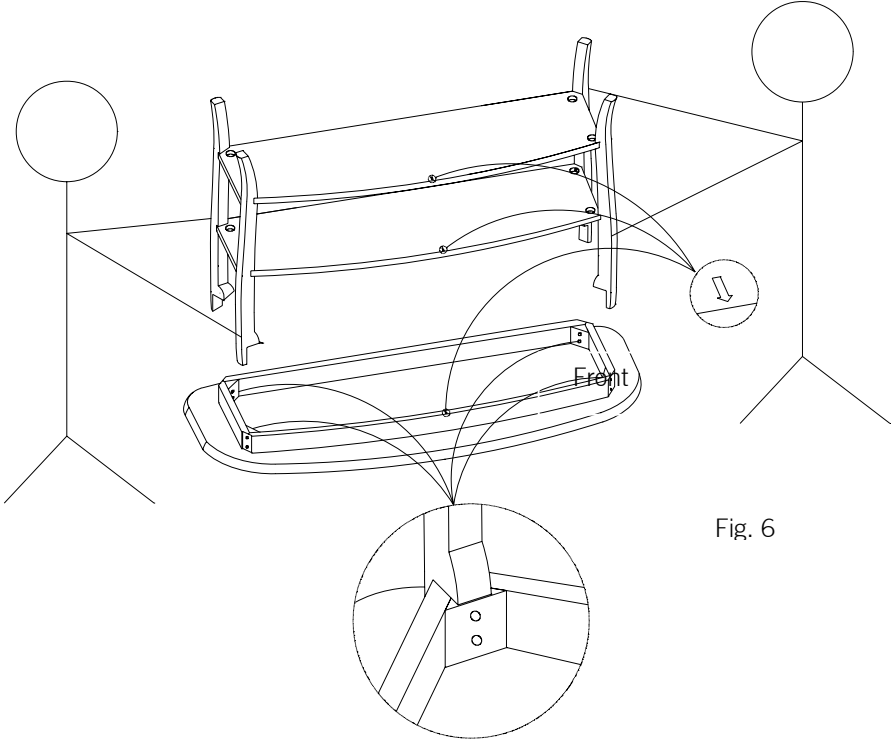

7. Insert a lock washer (E) and a flat washer (D) into Allen bolts (F). Insert bolts with washers through the pre-drilled corner holes of the tabletop (A) and into the legs (C). Use hand to screw half way then secure using the Allen key (G). (Fig. 7)

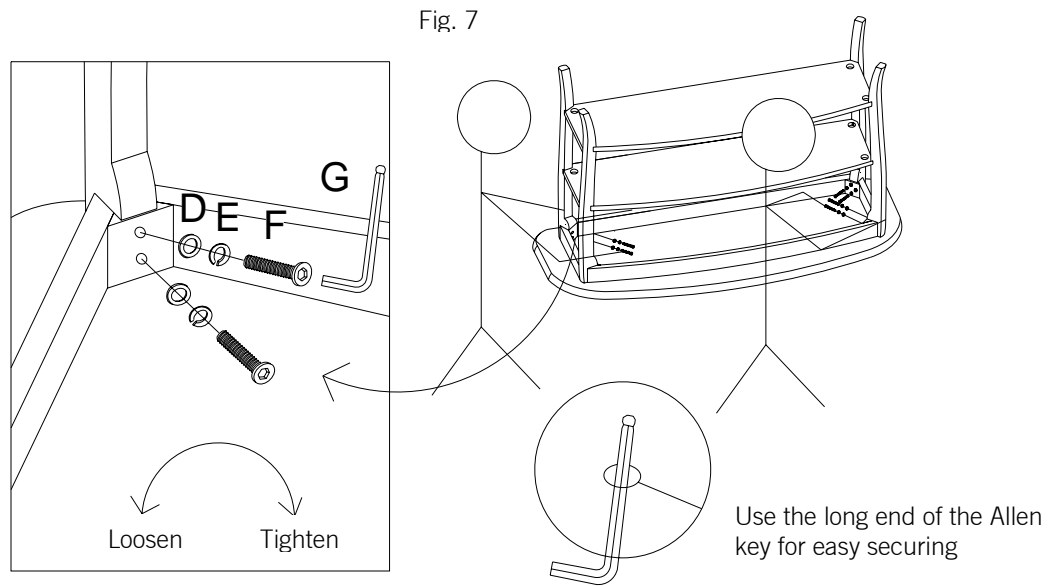

8. Use the Allen wrench (J) to tighten the middle shelf nuts (I). (Fig. 8)

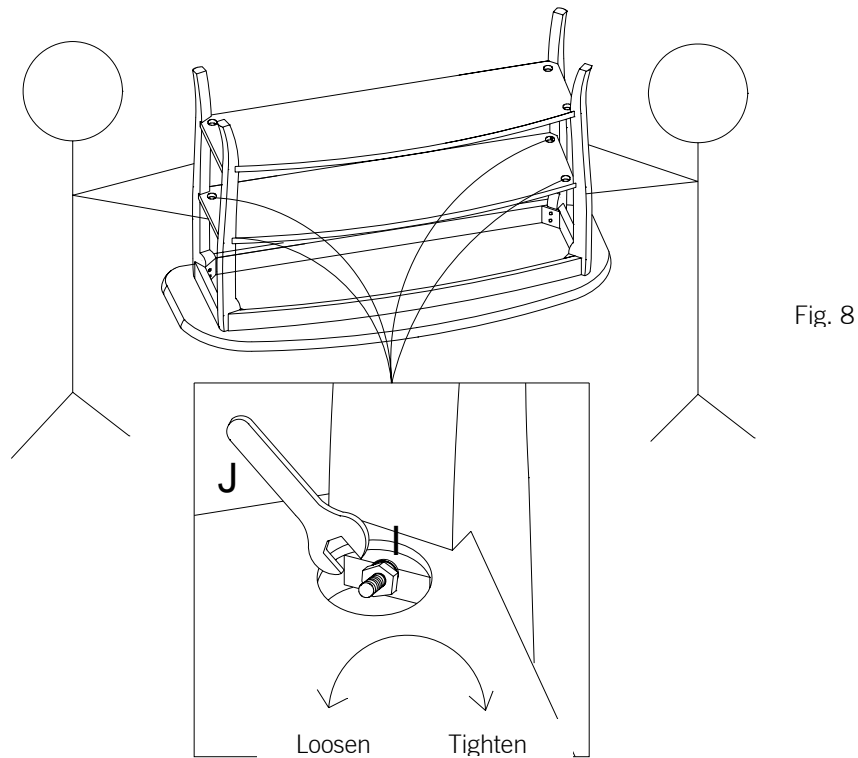

9. Use the Allen wrench (J) to tighten the bottom shelf nuts (I). (Fig. 9)

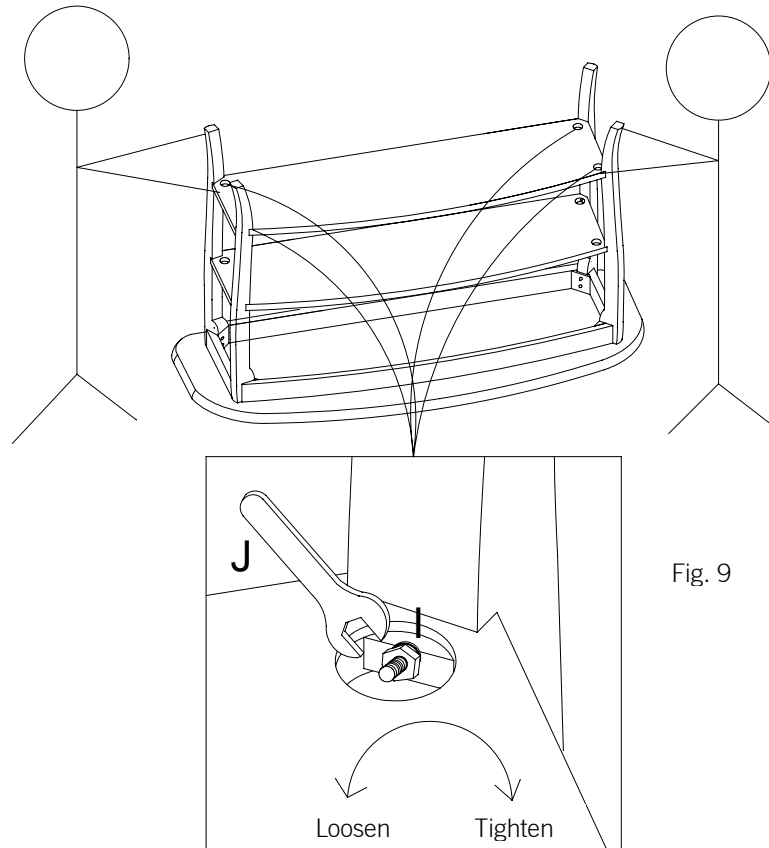

10. Secure and tighten all bolts and nuts. Grip the table on both ends and carefully turn upright. Assembly is complete. (Fig. 10)

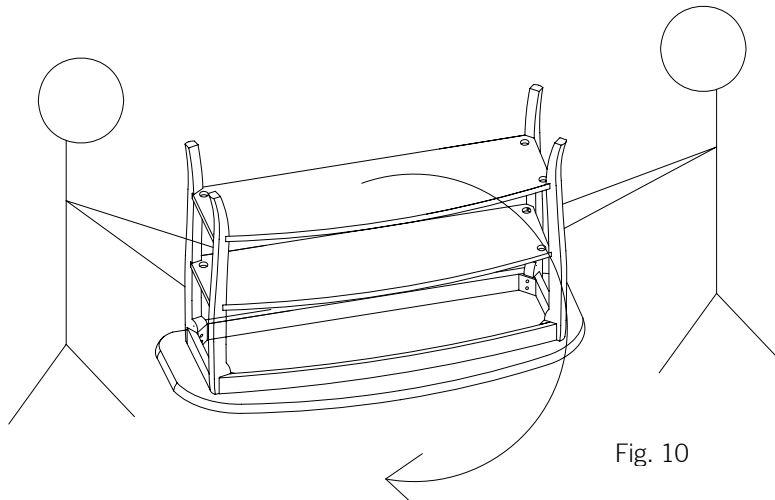

Care Instructions:

- For daily cleaning, wipe with a soft damp cloth.
- Wipe up spills immediately.
- Avoid the use of chemicals and harsh cleaning agents.
- The use of trivets and coasters is recommended to protect the tabletop.

thank you for your purchase
stores | catalog | www.potterybarn.com