

POTTERY BARN

Bedford Small Desktop with Legs Assembly Instructions

Pre-Assembly:

- Please read all instructions carefully before beginning assembly.
- For your safety and ease, assembly by two people is recommended.
- Use the parts and hardware lists to identify and separate each of the components included.
- Save all packing materials until assembly is complete to avoid the accidental discarding of smaller parts or hardware.

Parts Included:

- (1) Small Desktop (A)
- (1) Leg Set (B)

Hardware Included:

- (6) Allen Bolt – M8 x 50mm (a)
- (6) Flat Washer – M8 x 18mm (b)
- (6) Spring Washer – M8 x 15 (c)
- (1) Allen Key (d)

Needed for Assembly:

- (1) File Cabinet (sold separately)

Assembly Instructions:

1. Place the desktop (A) upside down on a carpeted or scratch-free work surface. The cardboard packaging can also be used as a work surface.
2. Determine which side the table legs will be installed. Align the 6 pre-drilled holes on the leg set (B) with the 6 pre-inserted nuts on the desktop (A). Insert an Allen bolt (a) with a spring washer (c) and flat washer (b) into each of the pre-drilled holes of the leg set (B) and into the desktop (A). Secure with the Allen key (d). Note: Do not tighten until all bolts are aligned and inserted. (Fig. 1).
3. Once the leg set (B) is securely fastened onto the desktop (A), grip the table and turn upright. Place the desktop with legs on the top of a file cabinet. (Fig. 2).
4. If the floor is uneven, adjust the recessed levelers found underneath each leg. To do this, carefully grasp the leg and elevate it slightly to provide access to the levelers. Turn the levelers until adequate contact is made with the floor. (Fig. 3)
5. Assembly is complete.

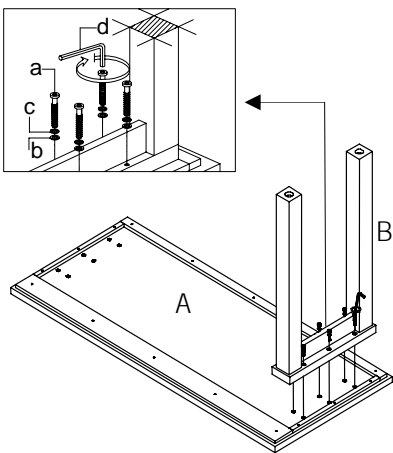

Fig. 1

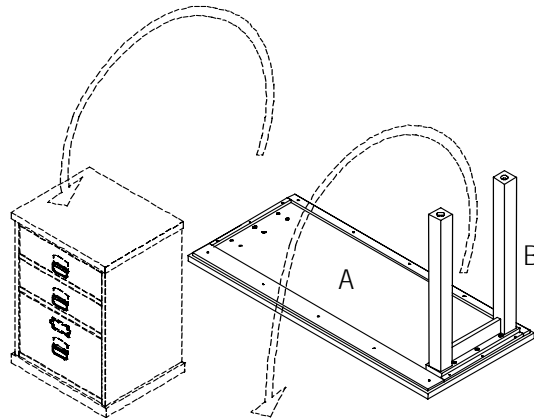

Fig. 2

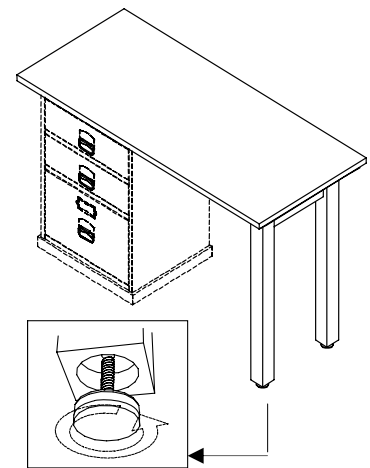

Fig. 3

Care Instructions:

- Wipe using a clean, soft, dry cloth.
- To protect the finish, avoid the use of all chemicals and harsh abrasives.
- A light application of furniture polish or wax may be used to restore the wood's finish.