

# P O T T E R Y B A R N

## Lucy Shoe Bench

### Assembly Instructions

**Hardware Included:** (4) Large Allen Screws, (8) Small Allen Screws (1) Allen Key

**Note:** Assembly by two people recommended. Open the box safely and unpack all the included items. Do not discard packing until assembly is completed.

#### Parts Included:

- (1) Metal Frame (A)
- (1) Wooden Legs (B)
- (1) Wooden Top (C)
- (1) Cushion (D)

**Step 1:** Place the wooden top (C) on the floor such that in four slots will be facing upwards. Now insert the legs into the provided slots of wooden Top (C) so that its through holes matches to the allen screw holes of the legs (B) insert small allen Screw, and tight with help of allen key provided.

**Step 2:** Now place the metal frame (A) in between the assembled wooden legs (B) and match the through holes of wooden leg (B) with the holes given on metal frame (A) insert Large allen screws into the through hole of wooden leg (B) and tight with the help of allen key provided.

**Step 3:** Now place the Lucy Shoe Bench to the right position as per the illustration and place the cushion (D) on the wooden Top (B).

Assembly is complete.

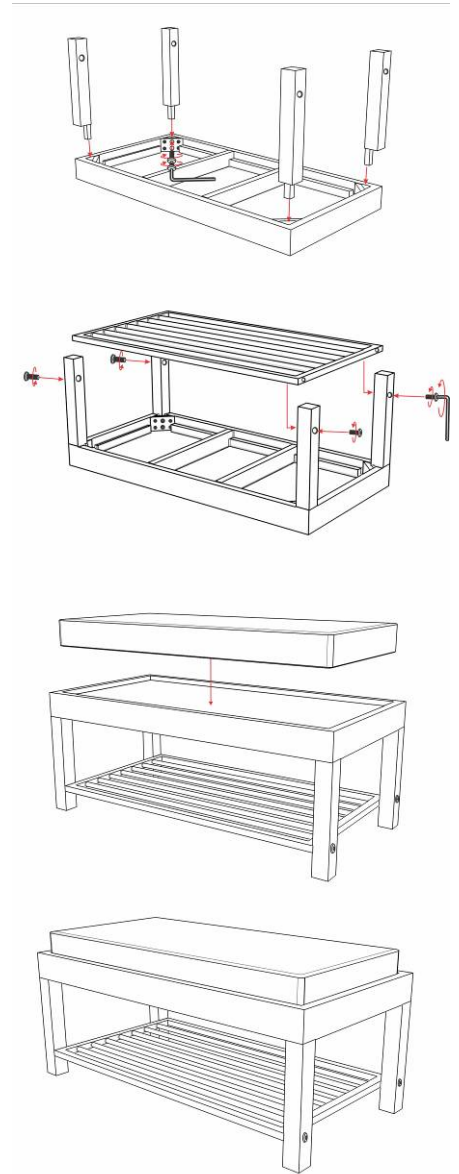

#### Care Instructions:

Wipe with a soft, dry cloth. Do not use any abrasive or chemical household cleaners.

Thank you for your purchase!  
Stores | Catalog | [www.potterybarn.com](http://www.potterybarn.com)