

P O T T E R Y B A R N

Metropolitan Side Table Assembly Instructions





Pre- Assembly:

- Please read all instructions before beginning assembly.
- For your safety and convenience, assembly by two people is recommended.
- Use the parts and hardware lists to identify and separate each of the components included.
- Save all packing materials until assembly is completed to avoid the accidental discarding of smaller parts or hardware.

Parts Enclosed:

- (1) Table top - A
- (4) Legs – B
- (1) Middle shelf – C (Does not have pre-drilled holes on corner wood blocks)
- (1) Bottom shelf – D (Has pre-drilled holes on corner wood blocks and is bigger than the middle shelf – C)

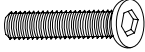
Hardware Included:

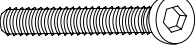
(8) Flat washers – E 	(8) Lock washers – F 	(4) Short Allen bolts – G  1/4" x 1-3/4"
(1) Allen key – H 	(4) Long Allen bolt – I  1/4" x 2-3/8"	

Assembly Instructions:

1. Lay the table top (A) upside down on a carpeted or scratch-free surface.
2. Attach the legs (B) to the table top (A) by aligning the pre-drilled holes on each leg with the pre-drilled holes on the corner braces of the table top (A). (Fig. 1)
3. Secure the legs using the flat washers (D), lock washers (E), and the short Allen bolts (F) with the Allen key (G). Do not fully tighten at this time. (Fig. 1)
4. Place the middle shelf (C) and the bottom shelf (D) on the open slots of the legs (B). (Fig. 3)
5. Insert the flat washers (D), lock washers (E) and long Allen bolts (H) into the pre-drilled holes on the corner wood blocks of the bottom shelf (D). Secure with the Allen key (G). (Fig. 2)
6. Tighten all bolts and screws.
7. Grip the table and carefully turn upright.
8. Assembly is complete.

Fig. 1

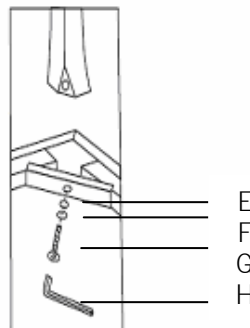

Fig. 2

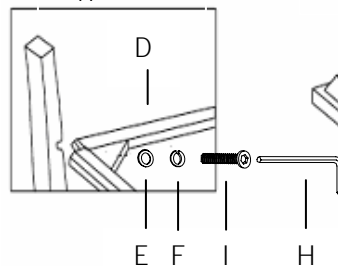

Fig. 3

